



Rack Mount/Table Top THC Analyzer

Heated FID 3-500

Low Cost 19" space saving rack mount and table top heated emission analyzer for the continuous determination of the mass concentration of total gaseous organic carbon using the Flame Ionization Detector method.

The 3-500 complies with QAL1 (EN 14181-EN ISO 14659), with EN 12619, EN 13526, US EPA Method 25A and US EPA Method 303



Low cost of ownership. Low fuel gas consumption. The combustion air supply for the FID detector built in. No external cylinder for synthetic air needed.

No heated block; To prevent hydrocarbon hang up (memory effect) and related drifting all components in contact with sample like detector, sample filter, sample pump and sample pressure restriction are discreetly mounted in a 190°C heated oven for easy straightforward servicing. The disposable heated sample filter cartridge is easily accessible in the rear panel.

General:

Fully complies with EN 14181 and EN ISO 14956, with EN 12619, EN 13526 (EU) and EPA Method 25A and Method 503 (USA)

The 3-500 heated FID is the low cost version of our widely used 3-300A Analyzer which has been sold thousandfold for more than 3 decades. The 3-500 has been brought to market when a number of long term users requested a lower cost but fully method 25A complying heated FID analyzer to be integrated into their CEM systems or used for VOC stack testing.

Like all our other heated FID analyzers the 3-500 is a highly reliable and outstandingly forgiving and rugged rack mount or table top heated total hydrocarbon analyzer. Built for fast response, very low drift, high accuracy, sensitivity and stability. The 3-500 uses a hydrogen flame ionization detector (FID) in a heated oven to prevent the loss of high molecular weight hydrocarbons and to provide reliable performance in the analysis of high concentrations down to very low trace concentration levels of gaseous organic carbon contaminants in emissions, air and other gases and high purity gases.

All sample containing parts and components are discretely integrated into an easy to maintain heated chamber. The disposable heated sample filter is easily reached in the rear panel and can be changed with a standard Allen key.

The combustion air supply for the detector is built in. No expensive air generator or external cylinder for synthetic air is needed.

The 3-500 is a standard emissions analyzer and therefore optimized for the accordance with the European EN-12619:2013 specifications. Several different target optimizations for “non EN-12619:20136” applications are available on request.



Analyzer Features

- x Made in Germany
- x 6 digit direct reading engineering unit (ppm or others) reading concentration display; No need for range change for up to 3 measuring ranged.
- x Standard VDC, mA and RS 232 data outputs.
- x Disposable sample filter easily accessible in the rear panel for filter change without special tools.
- x All components in contact with sample are fully heated and digitally maintained at 190°C.
- x Built-In sample pump.
- x Built-in combustion air pump and purifier, no extra burner air bottle needed.
- x Automatic flame out alarm contact and optional available fuel shut off valve.
- x Fast response less than 1 second @ sample inlet.
- x Low fuel consumption @ 100% and all 40/60% mixed fuel gases.
- x Microprocessor PID type temperature controller.
- x Automatic or remote range change are optional.

Applications

- x Compliance monitoring of source hydrocarbons following European EN 14181/ EN ISO 14659, EN 12619:2013 regulations, US-EPA Method 25A and Method 503.
- x Stack gas hydrocarbon emissions monitoring.
- x Vent gas hydrocarbon emissions monitoring.
- x Fence line (perimeter) monitoring.
- x Solvent recovery monitor for carbon bed break through.
- x Catalytic converter and thermal combustion testing.
- x Carbon adsorption regeneration control.
- x Raw exhaust vehicle emissions analysis.
- x Hydrocarbon contamination monitoring in air and other gases.
- x Detection of trace hydrocarbons in purity gases used in the semi conductor industry.
- x LEL monitor of solvent laden air.
- x Measuring engine combustion efficiency.
- x Mobile car emissions THC/CH4 monitoring during driving conditions. Requires ICM option.

ICM 35: Optional Built in NMHC Catalytic Converter; measure Total Hydrocarbons or Methane only

The internal Non Methane Hydrocarbon (NMHC) Cutter measures alternately either THC or Methane-Only (Total Gaseous Organic Carbon or Methane Carbon) concentrations with the 3-500 analyzer. **The proprietary NMHC catalytic cutter converts organic carbon into CO₂ + H₂O. The catalyst is operating at a precisely maintained temperature and is positioned upstream the sample input into the detector. Measurements are performed by passing through the catalyst or by bypassing the the catalyst. Selected by manually or automatic switching between the two modes, the sample flow is altered between the two streams of passing the catalyst or bypassing the catalyst via two 2/2 way direct acting solenoid valves with a minimum cycle time of 45 seconds per each stream. The cycle time is an operational parameter which can be performed manually by using a rear panel toggle switch or by using an available external timing device which can be programmed by the operator between minimal 45 seconds to maximal 24 hours. Optimal catalyst performance is guaranteed by using a microprocessor controlled temperature stabilization to ±1°C. Zero calibration must be performed by using a zero grade Nitrogen gas. Span calibration is performed by using a Methane in Air as Span Calibration Gas.**

Principle of Operation

The Heated Flame Ionization Detection (HFID) method is used to determine the presence of total hydrocarbon concentrations in gaseous samples. Burning hydrocarbon-free hydrogen in hydrocarbon-free air produces a negligible number of ions in the detector. Once a sample which contains any organic carbon matter is introduced into this flame, a very complex ionization process is started. This process creates a large number of ions. A high polarizing voltage is applied between the two electrodes around the burner nozzle and produces an electrostatic field. Now negative carbon ions migrate to the collector electrode and positive hydrogen ions migrate to the high voltage electrode. The so generated ionization current between the two electrodes is directly proportional to the hydrocarbon concentration in the sample that is burned by the flame. This signal is measured and amplified by a highly sensitive and stable electrometer amplifier unit. The FID response is linear over six orders of magnitude. The typical detection limit of the Detector is 100 ppb.

Our proprietary sample pressure regulator provides a controlled sample pressure and flow which gives admittance of a constant sample flow rate to the FID burner. This technique of using our non sample contact regulator is time proven for over 40 years by J.U.M. Engineering to provide the highest possible sample low flow rate stability at the lowest maintenance. Our compactly designed flow control module for fuel, ignition and air flow rates via low thermal mass needle valves use high precision pressure regulators. The needle valves are factory adjusted and sealed to ensure the optimization of the burner.

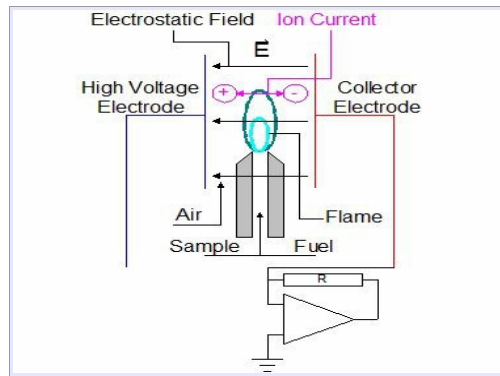

Detector Principle

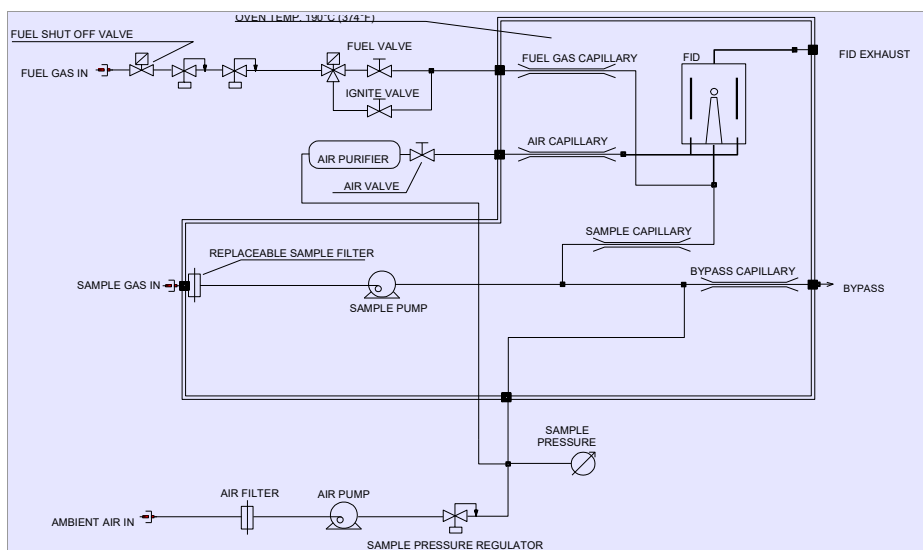

Complete flow diagram shown

Technical Specifications

Method	Heated Flame Ionization Detector (HFID)
Sensitivity	Max. 1 ppm CH ₄ full scale
Response time	@ sample inlet <0.5 seconds
t ₉₀ time	@ sample inlet <1.2 seconds
t ₉₀ time including 4X6mm heated sample line	Including heated sample line (7.5m) and sample probe filter filter: less than 8 seconds
Zero drift	<2% full scale / 24h
Span drift	<2% full scale / 24h
Linearity	Up to 10,000 ppm full scale within 1.5%
Oxygen synergism	< 2% FSD
Measuring ranges (ppm)	0-10,100, 1,000, 10,000, 100,000, others on request. Front panel turn switch. Automatic or remote range change optional
Concentration Display	6-digit direct reading ppm units. 24 bit high resolution. measure up to 3 overlapping ranges without range change
Signal outputs	0-10 VDC, 4-20 mA, including RS-232 data output
Total sample flow through Sample filter	2.5 to 2.8 l/min capacity @ operating temp. Permanent 2 micron mesh filter, cleaned by back purge with compressed dry air or N ₂ . Alternatively disposable change filter in rear panel. Option OW 7.
Zero and span adjust	Manual duo dial on front panel
Fuel gas choice	<ol style="list-style-type: none"> 1. Standard 100% H₂, consumption approx. 20 ml/min 2. Optional 40%H₂/60%He, consumption approximately 90 ml/min 3. Optional 40%N₂/60%He, consumption approximately 90 ml/min
Burner air consumption	Built in burner air supply. No external cylinder air needed. consumption approximately 130 ml/min @ 100% H ₂ fuel gas and approx. 220 ml/min at 40/60 mixed fuel gas
Oven temperature	190 °C (374 °F), digital PID controller
Power requirements	230VAC/50Hz, 850 W. 120 VAC/60Hz optional
Ambient temperature	5-43 °C (41-110 °F)
Dimensions (W x D x H)	19" (483 mm) x 460 mm x 132 mm
Weight	approx. 22 kg (50 lbs)

Options

AMU 35	Automatic controlled range change with range identification
AZM 35	Automatic flame ignition and re-ignition
FOAS 35	Flame out control with automatic fuel shut off valve
ICM 35 *	Built-in NMHC Cutter, measure either THC or Methane-Only concentrations with one analyzer
LTO 35	Measurement of low trace hydrocarbon levels. Requires external, zero grade combustion air supply
MBP 35 **	Integrated heated bypass pump for very long sample lines. It also compensates sample pressure fluctuations at sample inlet of up to 2 bar. <i>The MBP Option allows to feed another gas analyzer in series with the FID analyzer (for example NOx). Call for more details.</i>
RCA 35	0-20mA analog output instead of 4-20mA
RCIO 35	0-20 mA analog output, galvanic isolated
RCI4 35	4-20 mA analog output, galvanic isolated
TPR 35	External temperature controller for J.U.M. heated sample lines Model TJ 100 or other with "J" type thermocouple
	1.



J.U.M.® Engineering GmbH

Gauss-Str. 5, D-85757 Karlsfeld, Germany
Tel.: 49-(0)8131-50416, Fax: 49-(0)8131-98894
E-mail: info@jum.com
Internet: www.jum.com

© J.U.M. Engineering 2014/2020
Print Date: February 2020